

Freight Elevator Loading Classes

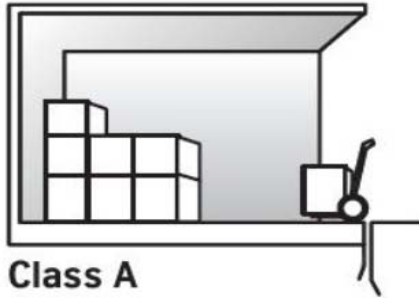

Class A

Class A

Weight of any one item or loaded truck cannot exceed 25% of the rated capacity of the elevator. Loads must be handled on and off car platform manually or by hand truck

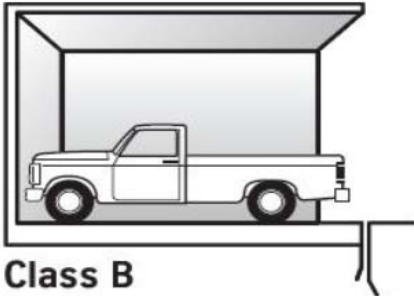

Class B

Class B

Elevator is used to carry automobile trucks or passenger automobiles. Doors must carry 75% of the rated load divided into two equal parts, 5'0" apart.

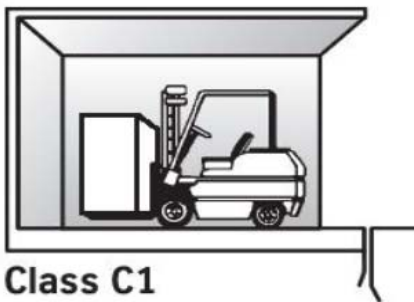

Class C1

Class C1

Industrial truck loading where truck is carried by the elevator. For rated capacity of 20,000 lbs or less, doors must carry 80% of the rated capacity divided into two equal parts, 30" apart.

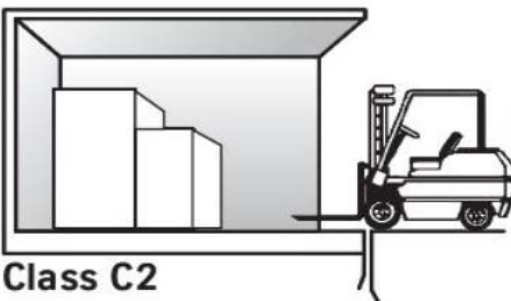

Class C2

Class C2

Industrial truck loading where truck is not carried by the elevator, but used only for loading and unloading. For rated capacity of 20,000 lbs or less, doors must carry 80% of the rated capacity or 80% of the loaded truck weight, whichever is greater, divided into two equal

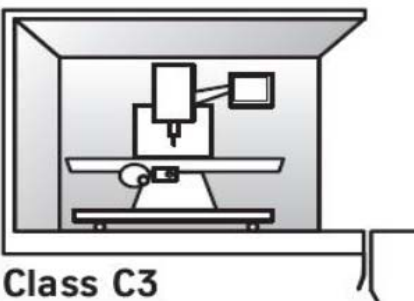

Class C3

Class C3

Other loading with heavy concentrations where trucks are not normally used, consult EMS Group for specific application.